



zzwancor

a Wienerberger company



Monolithisches
Einsteinmauerwerk
Poro-Therm
Warum... ?

zzwancor
a Wienerberger company

- 
- Idee
 - Entwicklung
 - Produktion
 - Wandkonstruktionen;
U-Wert und Kosten
 - Referenzobjekte



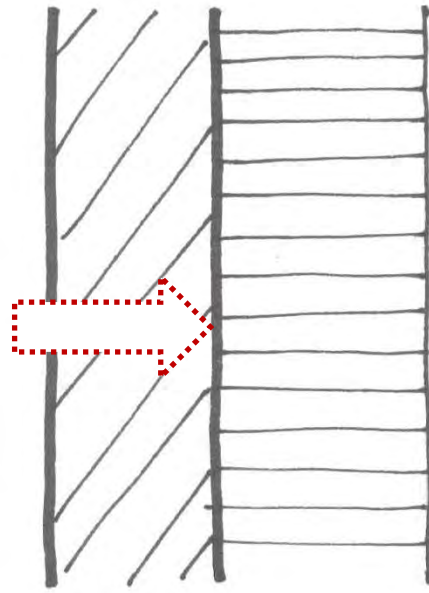
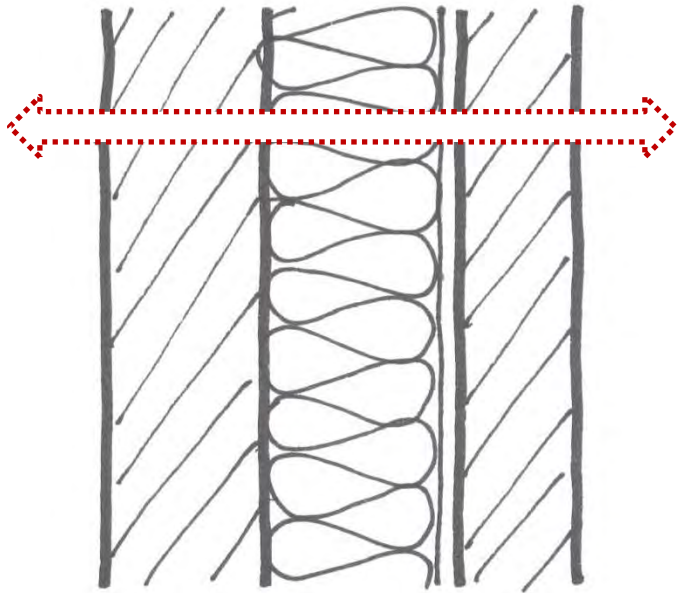

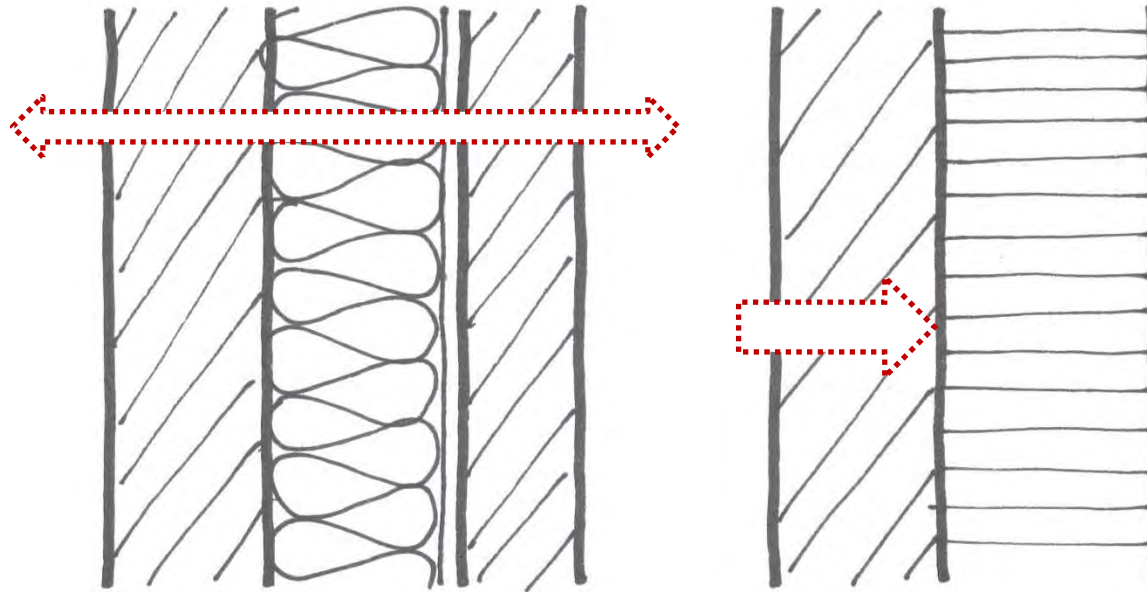

«Wir haben die Natur durch eine technische Umwelt ersetzt anstatt sinnvolle Zusammenhänge für den Nutzer entwickelt.» Dietmar Eberle

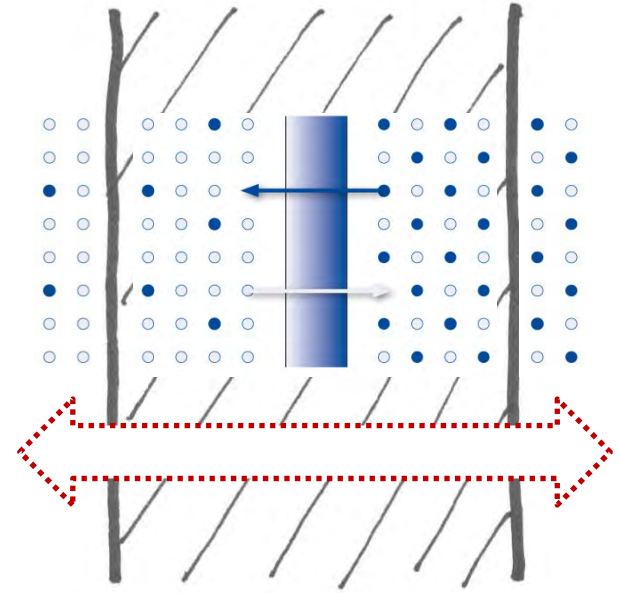
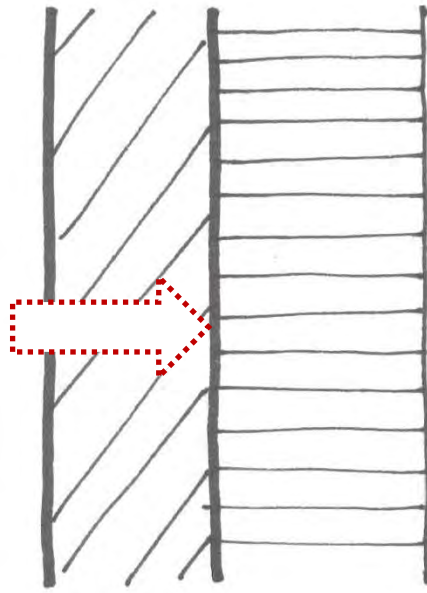
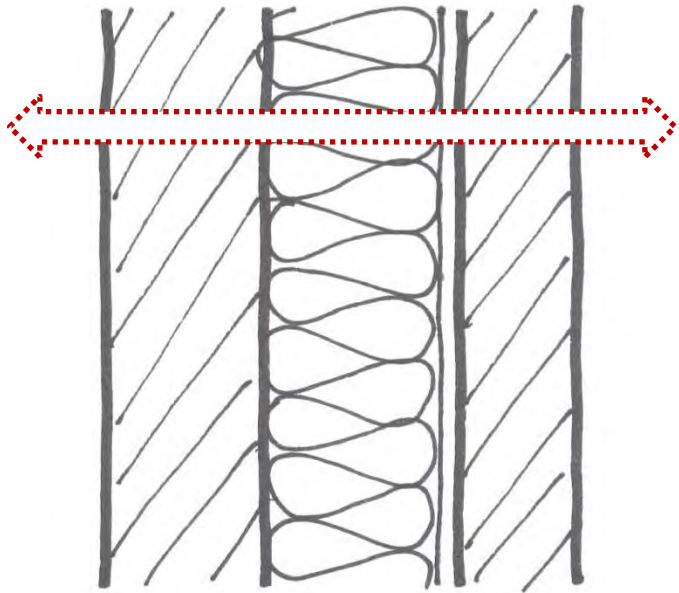

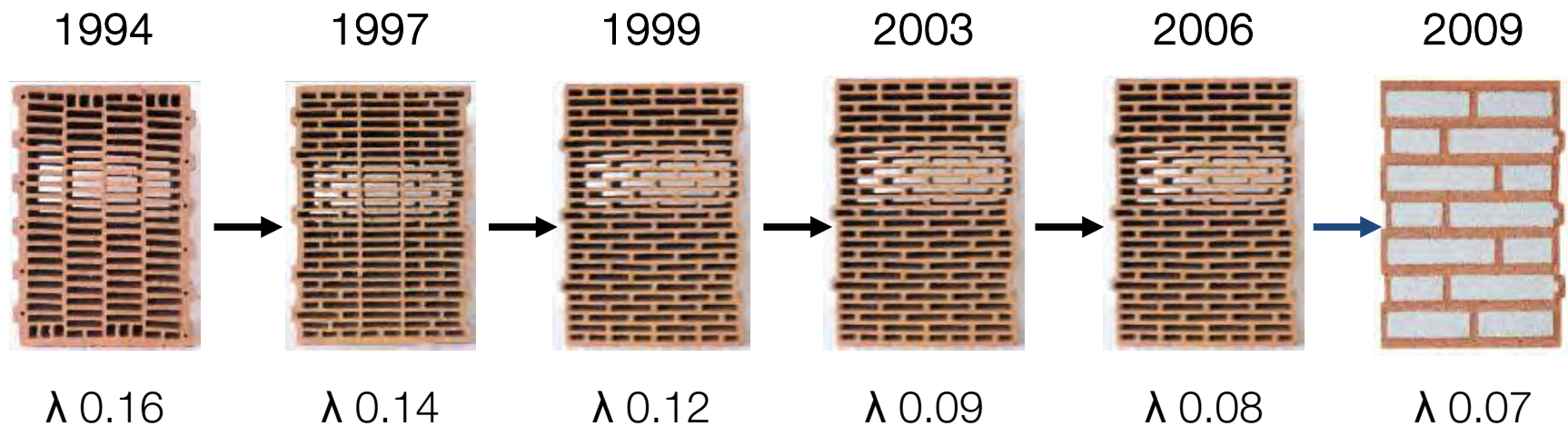

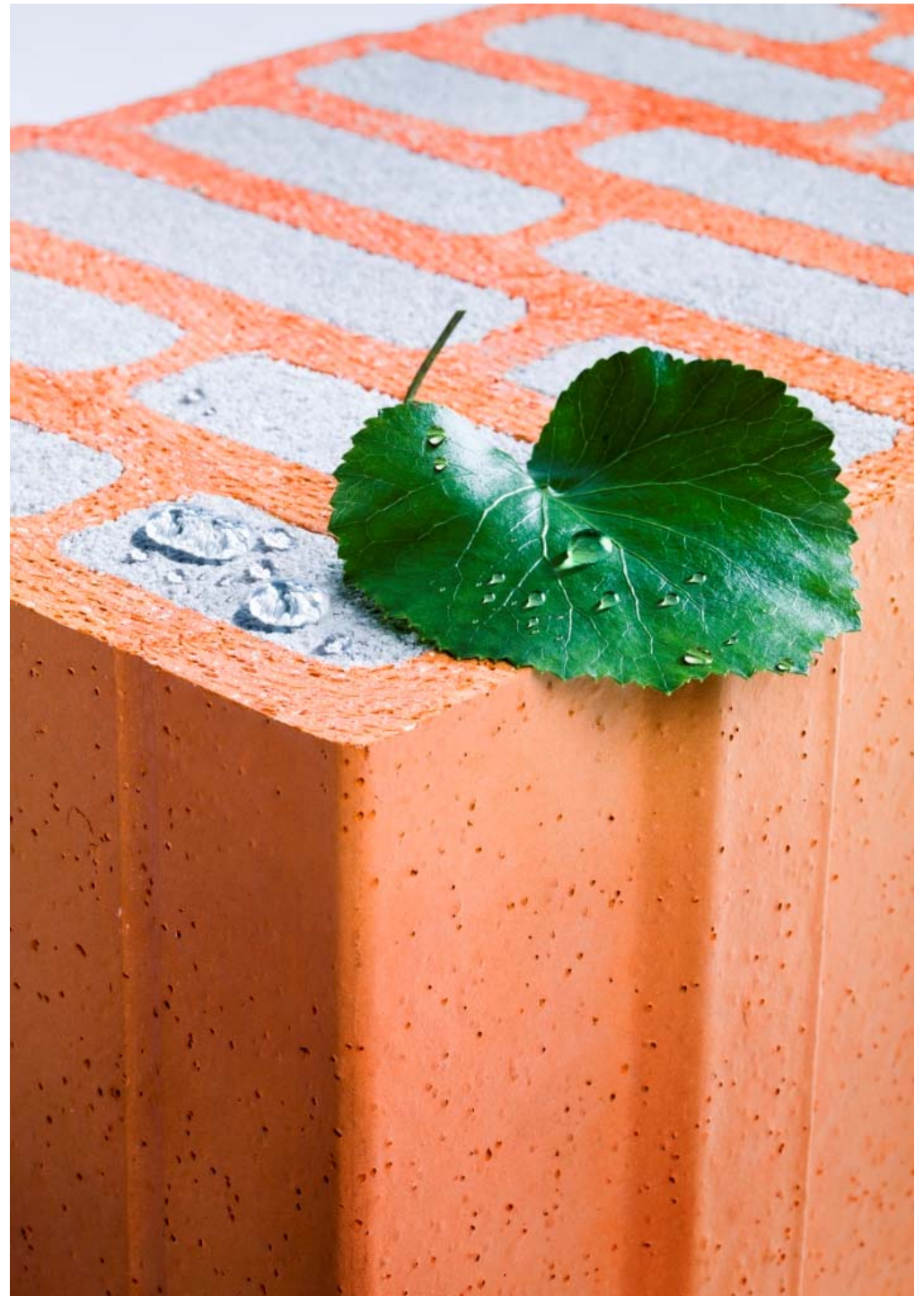
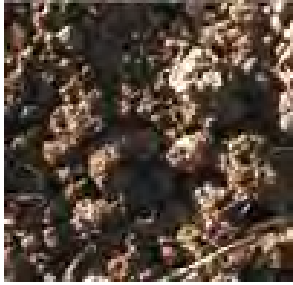





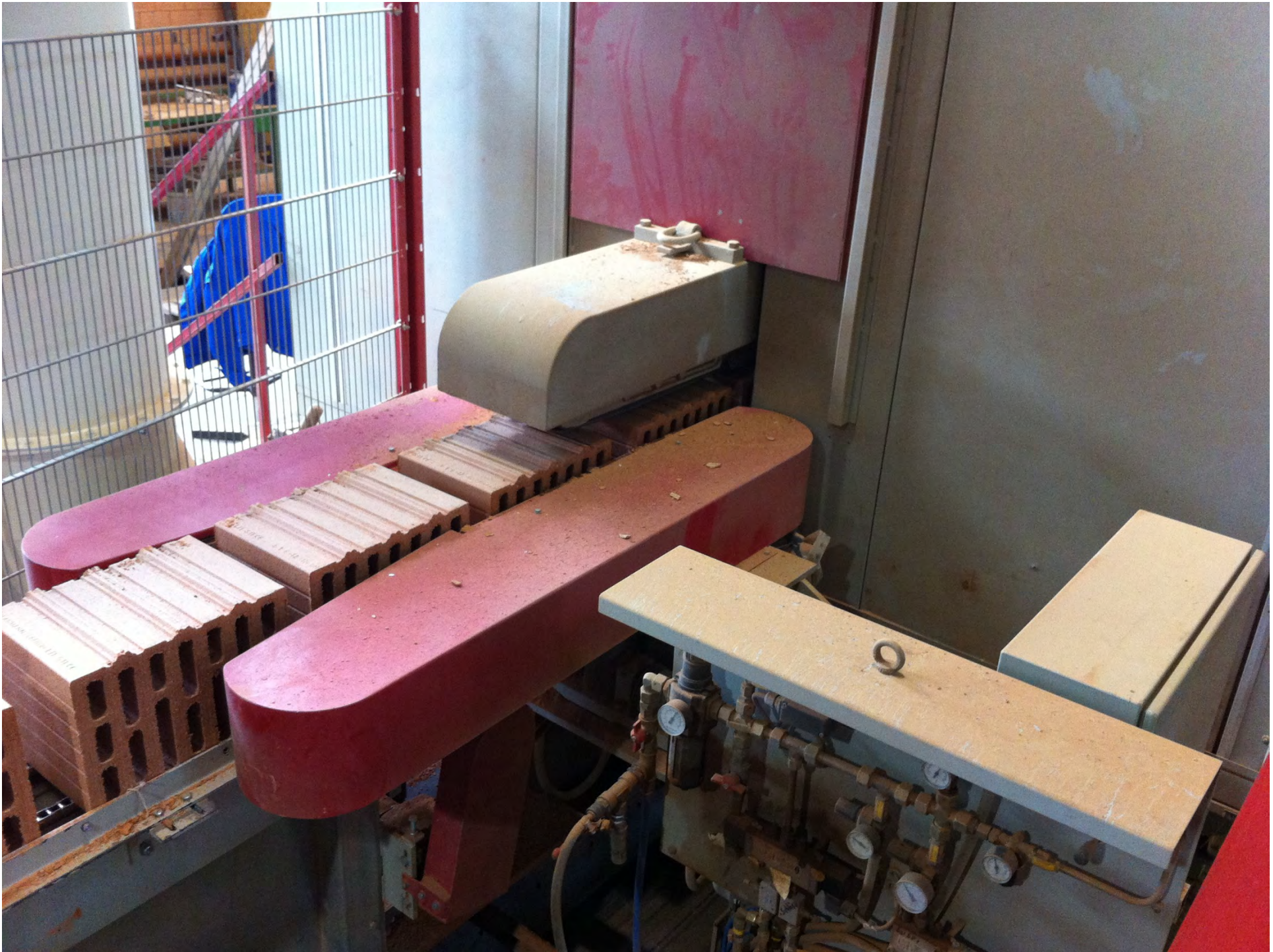

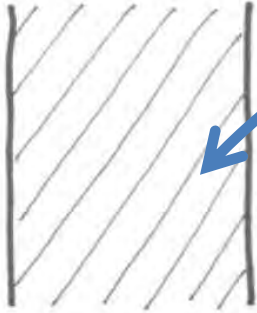
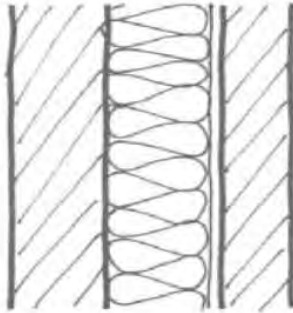
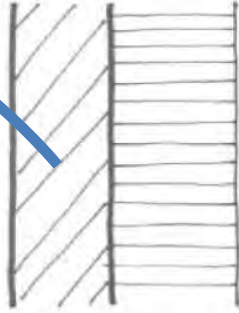

Konstruktion	Einsteinmauerwerk	2-Schalen-Mauerwerk	Backstein-Aussendämmung
U-Wert [W/(m²K)] 0.20	 Porotherm T8 - 365 / $\lambda=0.08$ Wandstärke = 36.5 cm Richtpreis: 280.- Fr. / m ² Porotherm S9 - 425 / $\lambda=0.09$ Wandstärke = 42.5 cm Richtpreis: 320.- Fr. / m ²	 Backstein, 17.5 cm Steinwolle, 14 cm, $\lambda=0.035$ Toleranzraum, 2 cm Backstein, 15 cm Wandstärke = 48.5 cm Richtpreis: 310.- Fr. / m ²	 Backstein, 17.5 cm EPS grau, 16 cm, $\lambda=0.032$ Wandstärke = 33.5 cm Richtpreis: 230.- Fr. / m ²
0.18	Porotherm T7 - 365 / $\lambda=0.07$ Wandstärke = 36.5 cm Richtpreis: 290.- Fr. / m ² Porotherm T8 - 425 / $\lambda=0.08$ Wandstärke = 42.5 cm Richtpreis: 310.- Fr. / m ²	Backstein, 17.5 cm Steinwolle, 16 cm, $\lambda=0.035$ Toleranzraum, 2 cm Backstein, 15 cm Wandstärke = 50.5 cm Richtpreis: 330.- Fr. / m ²	Backstein, 17.5 cm EPS grau, 18 cm, $\lambda=0.032$ Wandstärke = 35.5 cm Richtpreis: 245.- Fr. / m ²
0.16	Porotherm T7 - 425 / $\lambda=0.07$ Wandstärke = 42.5 cm Richtpreis: 320.- Fr. / m ² Porotherm T8 - 490 / $\lambda=0.08$ Wandstärke = 49 cm Richtpreis: 340.- Fr. / m ²	Backstein, 17.5 cm Steinwolle, 20 cm, $\lambda=0.035$ Toleranzraum, 2 cm Backstein, 15 cm Wandstärke = 54.5 cm Richtpreis: 350.- Fr. / m ²	Backstein, 17.5 cm EPS grau, 20 cm, $\lambda=0.032$ Wandstärke = 37.5 cm Richtpreis: 260.- Fr. / m ²
0.14	Porotherm T7 - 490 / $\lambda=0.07$ Wandstärke = 49 cm Richtpreis: 350.- Fr. / m ²	Backstein, 17.5 cm Steinwolle, 22 cm, $\lambda=0.035$ Toleranzraum, 2 cm Backstein, 15 cm Wandstärke = 59.5 cm Richtpreis: 360.- Fr. / m ²	Backstein, 17.5 cm EPS grau, 24 cm, $\lambda=0.032$ Wandstärke = 41.5 cm Richtpreis: 290.- Fr. / m ²

ca.
+15%

ca.
+10%





Wohnüberbauung Oberzelg, Winterthur – Sennhof (Objekt im Bau)
HGW Heimstätten – Genossenschaft, Hegistrasse 25, 8404 Winterthur



Überbauung Lindenareal, Steckborn (Objekt in der Ausschreibung)

Wohnbaugenossenschaft „Linde“, Seestrasse 123, 8266 Steckborn



Ersatzneubauten Zwingli – Talgutstrasse, Winterthur (Detailplanung)

Wohnbaugenossenschaft Talgut, Weberstrasse 83, 8400 Winterthur



Wohnsiedlung Obsthalde, Zürich – Affoltern (Objekt im Bau)

Baugenossenschaft Süd – Ost, Tulpenweg 18, 8051 Zürich

Neubau Alterswohnungen Blumenfeld, Altstätten (Objekt im Bau)

WBG Alterswohnungen Blumenfeld, Heidenstrasse 16, 9450 Altstätten

NeuBinz 111, Zürich (Objekt im Bau)

Pensionskasse Stiftung Abenrot, Güterstrasse 133, 4053 Basel

MFH Opfikerstr. 62/64, Wallisellen (Objekt im Bau)

Keller Immobilien – Treuhand AG, Kirchstrasse 1, 8304 Wallisellen

